

Automated Parcel Storage System

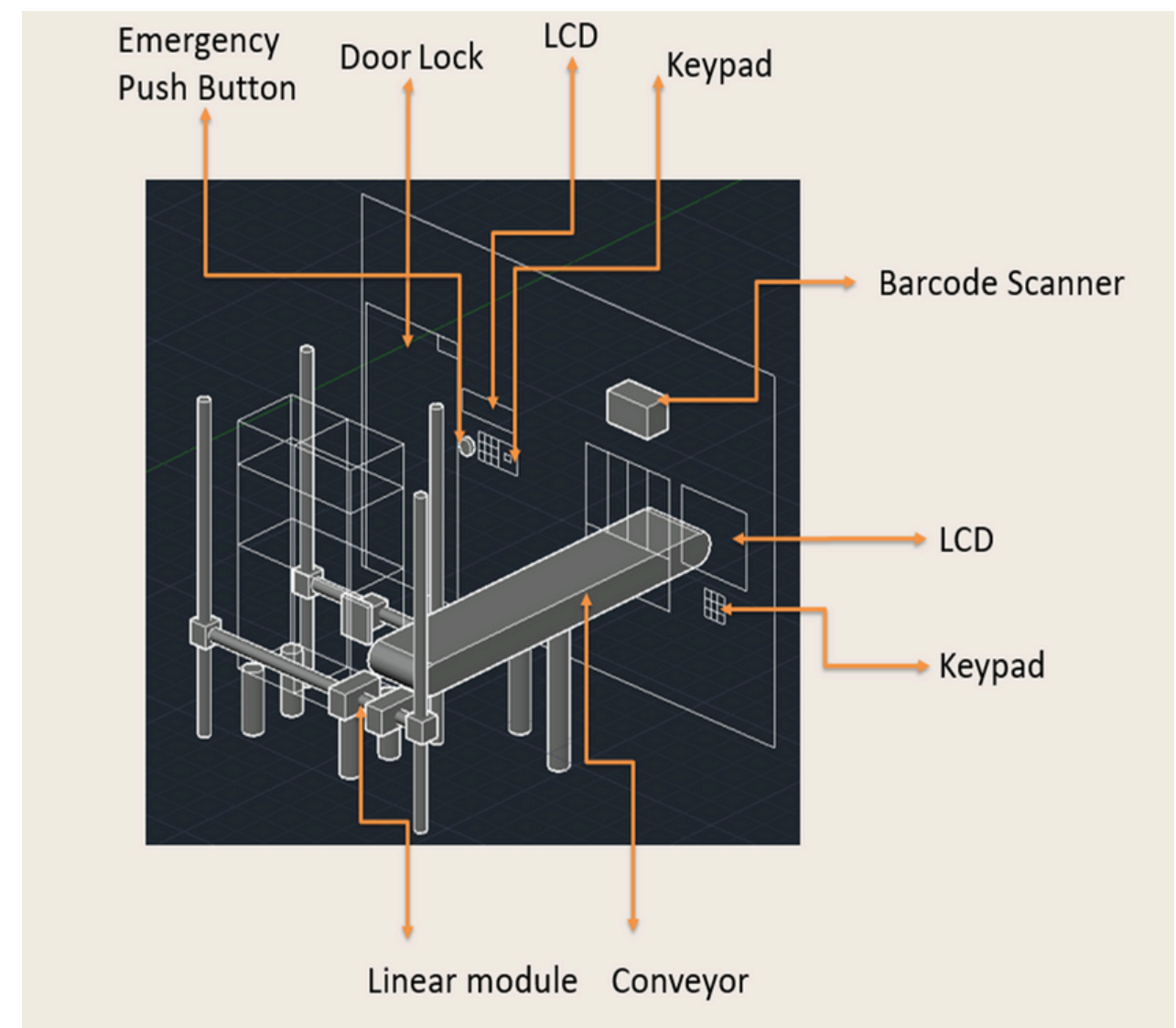

Introduction

- Courier Service be widely utilized.
- Always missed the parcel when during office time.
- Some Couriers will direct place the parcel front of the door.
- Increase the probability of parcel loss.
- Hence, plan to design an automated parcel transmission system.



Problem Statements

- Missed the parcels receive time when during office time.
- The expose of the parcel will be damaged or lost without protection and storage place.
- The general locker is inconvenience to the users.

Block Diagram

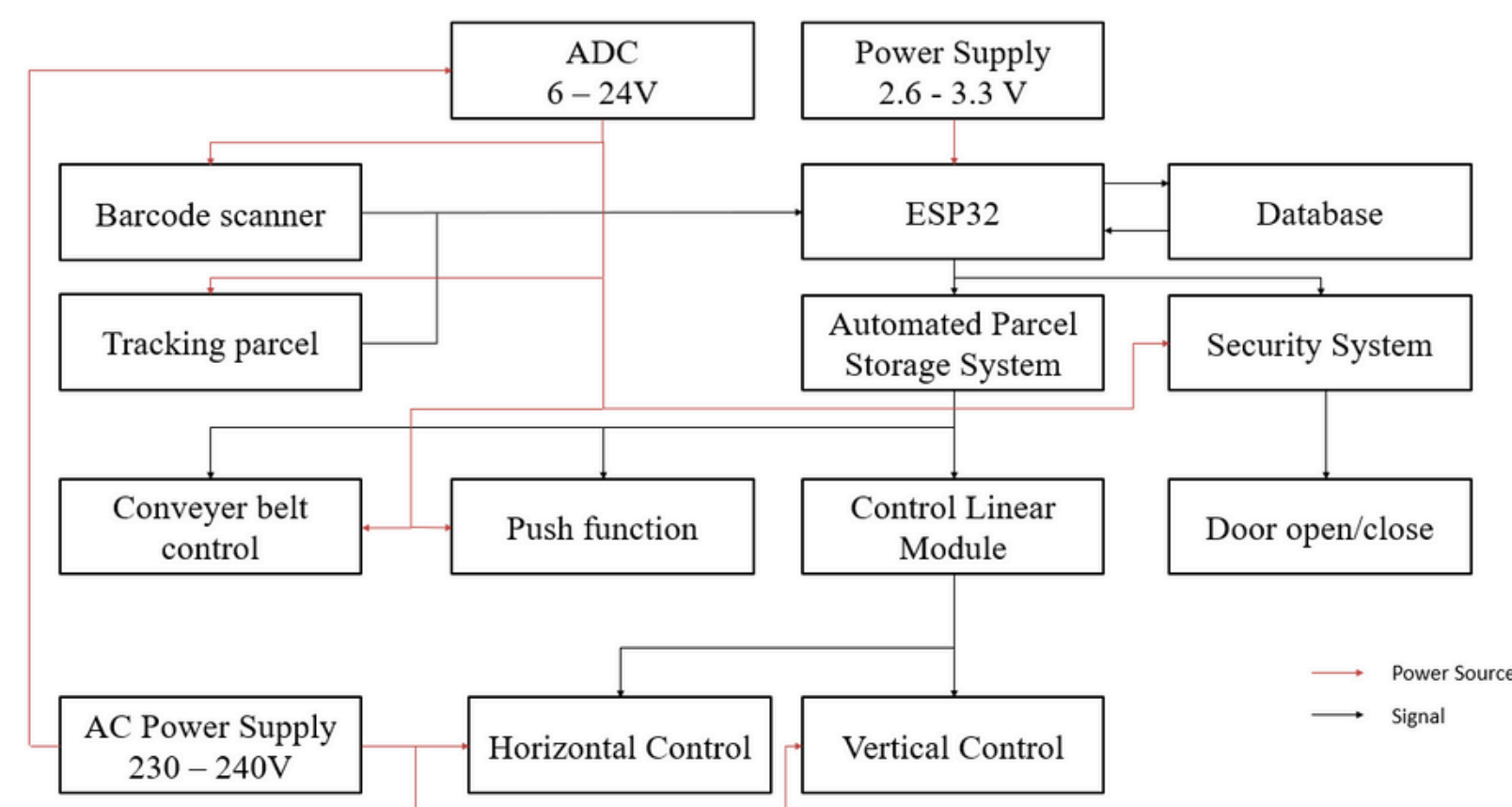

Potential Market

- Shopping mall
- Apartment / Hostel
- Company
- Residential area

Team Member

Ding Yu Fan | Ng Zhi Yong | Yap Jia Yu | Chan Bun Seng

ADDRESS:

Faculty of Engineering and Information Technology,
Southern University College,
Jalan Selatan Utama, Off Jalan Skudai, 81300 Skudai, Johor

Contact Info: dingyufan2073@gmail.com | youling20020521@gmail.com | yu201043@gmail.com