

JobFinder Online recruitment System

Background Research:

- Identify Target Market
- Job Posting & Application Process
- Data Privacy & Security
- Analytics & Metrics
- Search Engine Optimizing

Objective:

- To design a system that able to let employer to find employee that are require jobs.
- To enhance the efficiency that the employer to find the worker and the employee to a find a jobs.
- To test and validate the proposed system.

Technology:

- Laravel
- MySQL Database



Conclusion:

A description of the target market for the job portal, including the types of jobs and industries that are in demand, as well as the demographics of job seekers and employers who are likely to use the job portal.

Use Case:

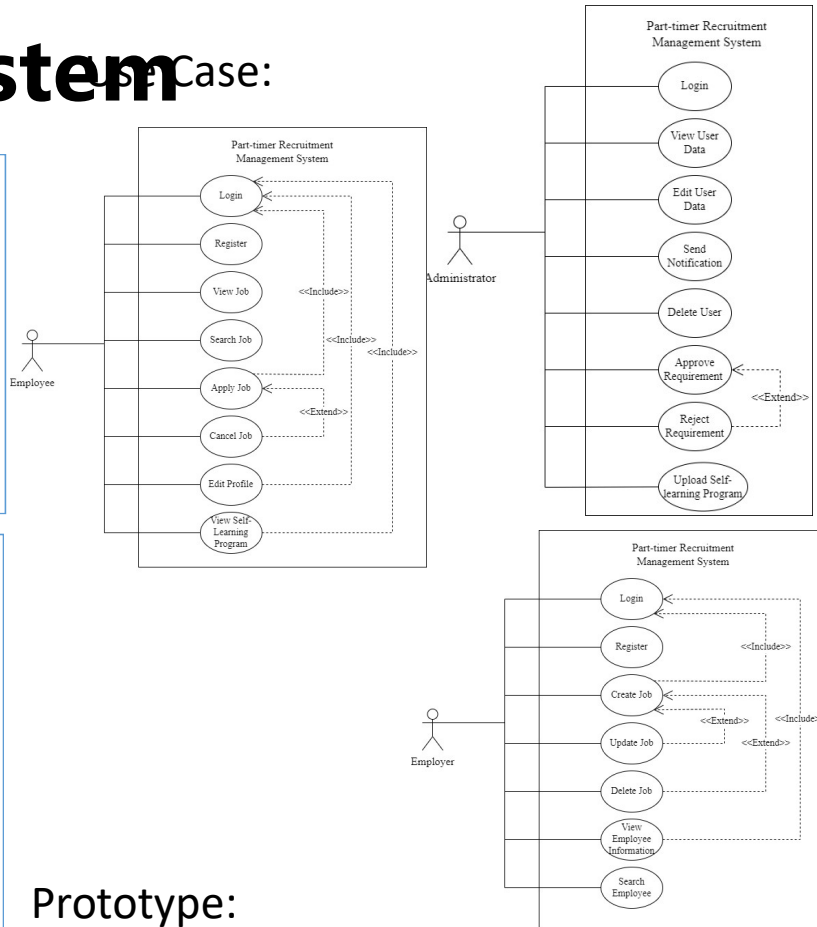

Prototype:

